

VSpoonDrain™ Open Channel Drainage



VSpoonDrain™ - channelling innovation

The **VSpoonDrain™ Open Channel Drainage System** brings smart design and fast installation together to give the ultimate open-channel drainage solution. VSpoonDrain is constructed using VantagePipe™ unique high strength, light weight reinforced concrete composite which enables the product to be quickly and efficiently installed.

VSpoonDrain is the product of choice for contractors seeking a different approach to open channel drainage systems

Fast. Smart. Proven. Strong.

vantagePipes™

VSpoonDrain™

Open Channel Drainage

Suited to a range of projects, the VSpoonDrain™ Open Channel Drainage system is constructed using high performance reinforced concrete pipe.

Using VSpoonDrain™ as permanent formwork allows quick construction with minimal hand finishing of placed concrete.

Available in sizes from 225mm up to 750mm, there is a size to suit any application.

Concrete Plinth Installation

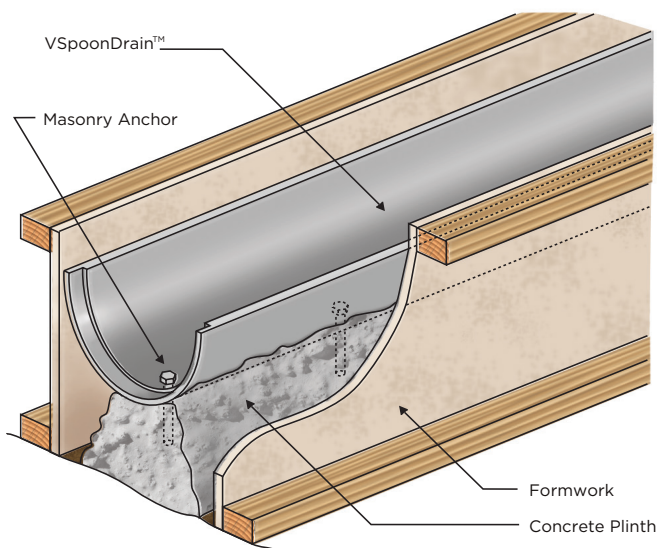

VSpoonDrain is not only versatile, it is proven and can be used for many applications including:

- Back of barrier drainage for retaining walls
- Drainage along the bottom of cuttings and retaining walls
- Channel drains alongside hardstand areas (grated covers can be used if required)
- Forming an open drain into concrete slabs.

Timber Hanger Installation

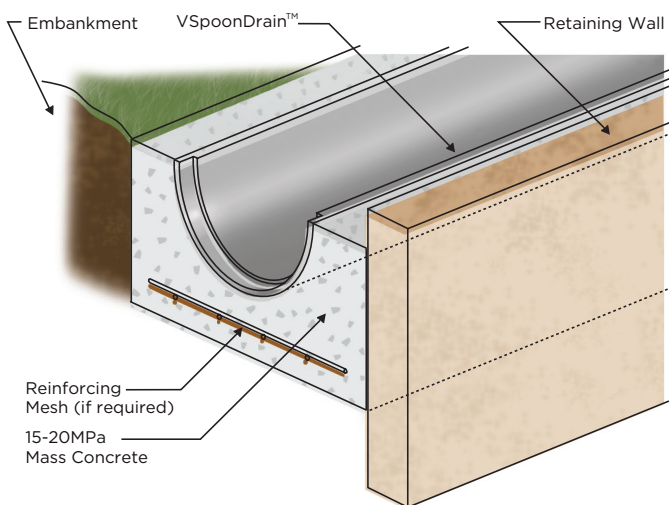
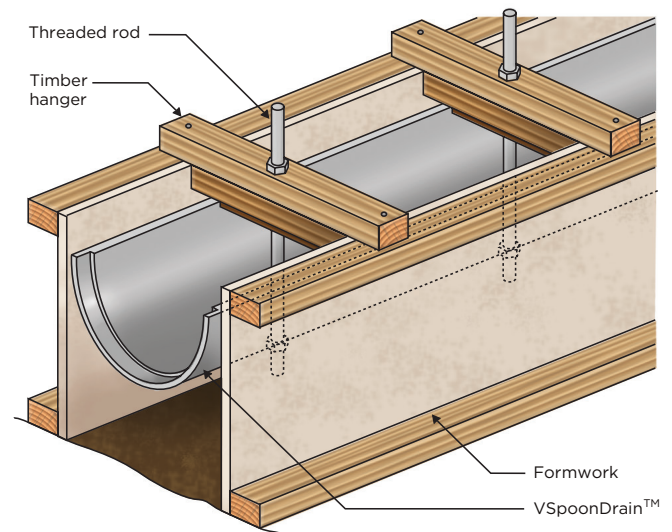

VSpoonDrain™ Open Channel Drainage		
Sizes (mm)	Product Code	Approx.Mass (kg)
225	403128	49
300	403144	70
375	403165	98
450	402436	137
525	402368	172
600	402400	222
750	403890	314

Fast. Smart. Proven. Strong.
1800 659 850 | VantagePipes.com.au

VantagePipes™